

Overview

HP Integrity rx6600 System Overview (Interior View)

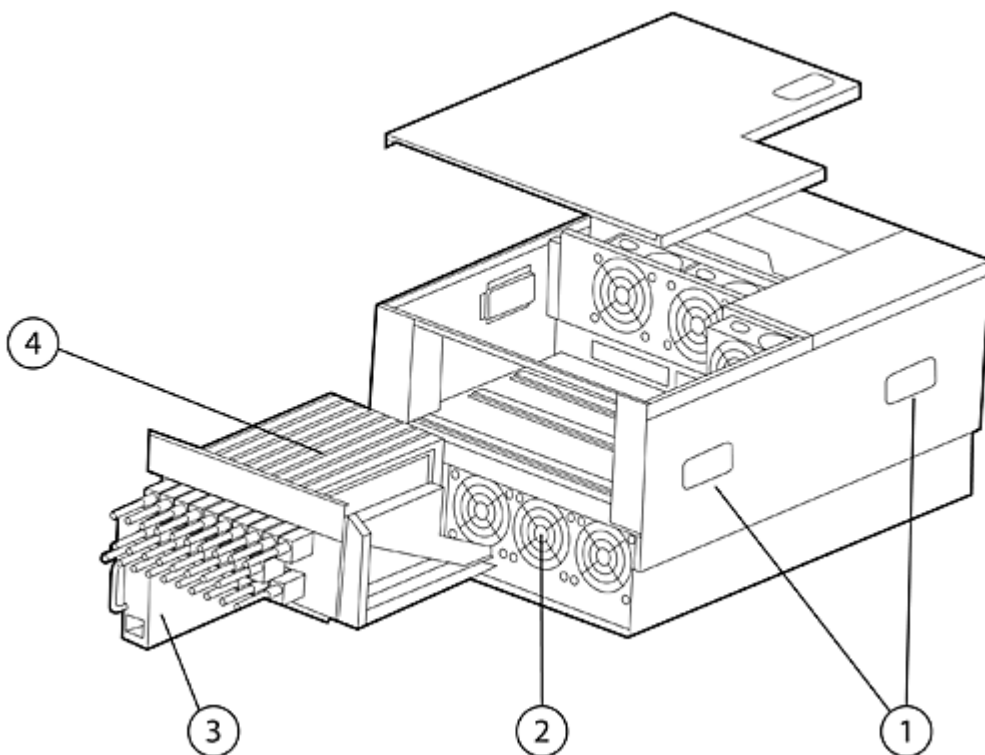

- 1. Recessed Carrying Handles
- 2. Redundant Bulk Power

- 3. 8 Hot Plug PCI-X 10 Slots (2 @ 266 MHz)
- 4. Hot Swap Fans

HP Integrity rx6600

Overview

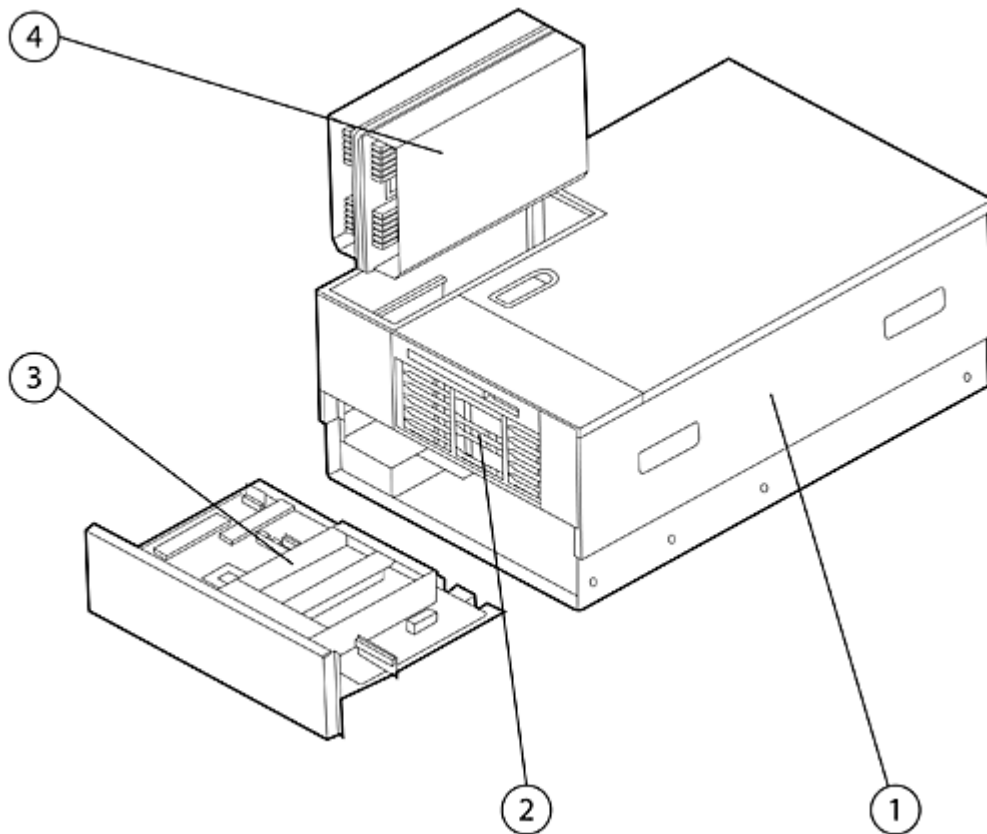

- 1. 7U Chassis
- 2. 16 SAS HDDs

- 3. 4 Clamshell CPU Sockets
- 4. 48 DDR2 DIMM Slots

Standard Features

Minimum System

- One 64-bit dual-core Intel Itanium 2 processor; either 1.6-GHz/24 MB cache, or 1.6 GHz/18 MB cache, or 1.4 GHz/12 MB cache; or 1.6 GHz/24 MB 9150N processor, or 1.6 GHz/18 MB 9140N processor, or 1.4 GHz/12 MB 9120N processor
- One I/O backplane. Either PCI-X 2.0 backplane with 8 available slots or PCI-Express backplane with 8 available slots
- 2-GB PC2 4200 ECC×4 Single Rank Registered DDR2 SDRAMs (4×512MB DIMMs)
- 24 DIMM slots (1×24 DIMM slot memory carrier board)
- One hot swap power supply

Maximum Server Capacities

- Four dual core 64 bit Intel Itanium 2 processors; either 1.6 GHz/24 MB cache, or 1.6 GHz/18 MB cache, or 1.4 GHz/12 MB cache; or 1.6 GHz/24 MB 9150N processor, or 1.6 GHz/18 MB 9140N processor, or 1.4 GHz/12 MB 9120N processor
- One I/O backplane. Either PCI-X 2.0 backplane with 8 available slots or PCI-Express backplane with 8 available slots
- 192 GB PC2 4200 ECC×4 Single Rank Registered DDR2 SDRAMs (24×4 GB DIMMs)
- 48 DIMM slots (2×24 DIMM slot memory carrier boards)
- Sixteen Serial Attached SCSI (SAS) disk drives
- Two hot swap power supplies (two supplies enables redundancy)

Standard System Features

- Operating System support: HP UX 11i version 2 June 2006 Update, HP UX 11i v3, Linux RHEL AS 4 U4 and SLES 10, OpenVMS V8.3 or higher for Integrity Servers and Microsoft Windows Server 2003 Enterprise and Datacenter Edition
- Choice of core storage card.
For HP-UX and OpenVMS-based systems: Must select one of two choices: PCI-X 8 port Serial Attached SCSI (SAS) host bus adapter or PCI-Express 8-port Smart Array (P400) Serial Attached SCSI Controller:
 1. The PCI-X 8-port Serial Attached SCSI (SAS) host bus adapter: Card will be installed in reserved core PCI-X I/O slot #1. This card supports up to two internal RAID 1 volumes (2×2 HDDs) and a disk for global hot spare, for a maximum of five disks in RAIDed arrays for HP UX and OpenVMS. The additional three drives (of the maximum of eight drives supported) can be accessed normally, but not configured for RAID. Factory set up of RAID 1 configurations is supported. When a second SAS Controller is required to support disks 9 through 16, it cannot be factory configured for RAID (unless it is done through Factory Express) . For customer/field configured RAID arrays, the same limitations (two RAID 1 arrays and one global hot spare) exist. The additional three HDDs (14 through 16) can be accessed normally, but not configured for RAID. Please see rx6600 Ordering Guide for factory configuration details. Note: MirrorDisk/UX is available for SW Mirroring on all HDDs in HP UX based systems and HP Volume Shadowing Level 1 for HDDs in OpenVMS-based systems.
 2. PCI-Express 8-port Smart Array (P400) Serial Attached SCSI Controller: Requires PCI-Express Backplane (AD296A Option Code 200); card will be installed in public slot #3, leaving 3 available PCI-Express slots and 4 available PCI-X slots. This card supports internal RAID-1, 5 and 6 configurations. RAID-1 requires a minimum of two identical HDDs, RAID-5 requires a minimum of three identical HDDs, and RAID-6 requires a minimum of four identical HDDs. When a second core PCI-Express P400 RAID controller is required to support disks 9 through 16, it will be installed in slot #4, leaving two available PCI-Express slots and four available PCI-X slots. Second core controller cannot be factory configured for RAID (unless it is done through Factory Express). Please see rx6600 Ordering Guide for factory configuration details. **NOTE:** MirrorDisk/UX is available for SW Mirroring on all HDDs in HP UX based systems and HP Volume Shadowing Level 1 for HDDs in OpenVMS-based systems.

Standard Features

For Windows and Linux based systems: Must select one of three choices: PCI-X 8 port Smart Array (P600) Serial Attached SCSI (SAS) controller, or PCI-Express 8-port Smart Array (P400) Serial Attached SCSI Controller, or PCI-Express 16-port Smart Array (P800) Serial Attached SCSI Controller.

1. PCI-X 8-port Smart Array (P600) Serial Attached SCSI (SAS) controller:

Card will be installed in reserved core PCI-X I/O slot #1. Supports internal RAID 1, 5 and 6 configurations.. RAID 1 requires two identical HDDs, RAID 5 requires three identical HDDs, and RAID 6 requires four identical HDDs. Factory set up of RAID 1, 5 and 6 configurations with Smart Array SAS controller is also supported. When a second SAS Controller is required to support disks 9 through 16, it cannot be factory configured for RAID (unless it is done through Factory Express) . For customer/field configured RAID arrays, all eight HDDs (9 through 16) can be configured for RAID levels 1, 5 and 6 in any combination. Please see rx6600 Ordering Guide for details.

2. PCI-Express 8-port Smart Array (P400) Serial Attached SCSI (SAS) controller.

Requires PCI-Express Backplane (AD296A Option Code 200); card will be installed in public slot #3, leaving 3 available PCI-Express slots and 4 available PCI-X slots. This card supports internal RAID-1, 5 and 6 configurations. RAID-1 requires a minimum of two identical HDDs, RAID-5 requires a minimum of three identical HDDs, and RAID-6 requires a minimum of four identical HDDs. When a second core PCI-Express P400 RAID controller is required to support disks 9 through 16, it will be installed in slot #4, leaving two available PCI-Express slots and four available PCI-X slots. Second core controller cannot be factory configured for RAID (unless it is done through Factory Express). Please see rx6600 Ordering Guide for factory configuration details.

3. PCI-Express 16-port Smart Array (P800) Serial Attached SCSI (SAS) controller:

Requires PCI-Express Backplane (AD296A Option Code 200); card will be installed in public slot #3, leaving 3 available PCI-Express slots and 4 available PCI-X slots. This card supports internal and external RAID-1, 5 and 6 configurations. RAID-1 requires a minimum of two identical HDDs, RAID-5 requires a minimum of three identical HDDs, and RAID-6 requires a minimum of four identical HDDs. When a second core PCI-Express P800 RAID controller is required to support disks 9 through 16, it will be installed in slot #4, leaving two available PCI-Express slots and four available PCI-X slots. Second core controller cannot be factory configured for RAID (unless it is done through Factory Express). Please see rx6600 Ordering Guide for factory configuration details.

- Core PCI-X dual port 10/100/1000Base TX LAN (with auto speed sensing; RJ 45 connector, Wake On LAN support)
- Integrated iLO2 Management Processor for remote management and HA monitoring
- Telnet and web console via 10/100Base TX management LAN (RJ 45 connector)
- Two RS 232 serial ports, one for console from the integrated management processor and one from the processor dependent hardware bus (PDH)
- Factory integration of processors, memory, disk drives, removable media, I/O cards, and HP Universal 10000 G2 series racks.
- Rackmountable into 19 inch cabinets-HP Universal 10000 G2 series as well as many third party racks, including field integration into existing HP System E racks
- Optional stand alone pedestal mount, field installation only.
- Three year warranty with next business day on site.

Standard Features

High Availability

- N+1 Hot swap cooling
- One Hot swap power supply-optional second power supply for N+1 protection
- Hot Plug PCI X I/O slots (Note: Some I/O cards do not support hot plugging. Please see Supported I/O card Table 3 this chapter for details.)
- On line memory page deallocation
- ECC protected DDR2 memory
- Memory double chip spare to overcome single DRAM chip failures
- Dynamic Processor resilience and deallocation
- UPS power management
- Hot Plug internal disks
- Internal RAID support. See Standard Systems Features on previous page and rx6600 Ordering Guide for various levels of RAID support.
- Journal file system with HP UX
- Auto reboot
- HP Serviceguard for HP UX
- HP Serviceguard Extension for RAC for HP UX
- HP Serviceguard Extension for SAP for HP UX
- Serviceguard Manager for HP UX and Linux Clusters
- HP Event Monitoring Service
- HA Monitors for HP UX
- HA Toolkits for HP UX and Linux
- HP Mirrordisk/UX
- Extended Campus Cluster, HP Metrocluster, and HP Continentalclusters for HP UX
- HP OpenVMS clusters
- HP Volume Shadowing for OpenVMS
- HP RMS Journaling for OpenVMS
- HP System Insight Manager (SIM) for proactive fault management
- Microsoft Cluster Service for Windows Server 2003 Enterprise Edition
- HP StorageWorks Software for HP Integrity Servers running Windows Server 2003 Enterprise Edition. Includes Cluster Extension XP and EVA, Continuous Access, Business Copy and SQL Server Fast Recovery
- HP StorageWorks Cluster Extension XP for Linux

Security

- Separate LAN for system management
 - Password protection on console port
 - Disablement of remote console ports
 - SSL encryption on web console
-

Standard Features

Manageability - Deploy

- HP Ignite UX for installation and deployment of the operating system
- HP Software Distributor UX for software and patch management
- HP Integrity Essentials Foundation Pack for Linux
- HP Integrity Essentials Foundation Pack for Windows including Smart Setup CD for easy server setup and configuration

Manageability - Monitor

- Built in Integrity iLO 2 Management Processor for comprehensive remote server management of HP UX, Linux, Windows and OpenVMS
- HP Servicecontrol suite for HP UX servers including tools for system administration, asset management, and fault management
- HP UX kernel configuration for easy, dynamic kernel parameter changes
- HP System Insight Manager (SIM)

Manageability - Optimize

- Process Resource Manager for HP UX resource management
- HP UX Workload Manager for HP UX workload management based upon service level objectives
- HP OpenView GlancePlus Pack
- HP Intelligent Networking Pack for Windows
- HP Performance Management Pack for Windows
- Windows System Resource Manager (included with each copy of Windows Server 2003 Enterprise Edition)

Configuration

Processor Configuration The HP Integrity rx6600 is a symmetrical multiprocessing (SMP) server supporting up to four high performance 64 bit dual core Intel Itanium processors. The dual core Intel Itanium processor supports hyper threading. Each core of the processor supports two threads.

Processor Details Dual core Intel Itanium processors:

- 1.6 GHz with 24 MB Level 3 Cache, 12 MB per core processor
- 1.6 GHz with 24 MB Level 3 Cache, 12 MB per core 9150N processor
- 1.6 GHz with 18 MB Level 3 Cache, 9 MB per core processor
- 1.6 GHz with 18 MB Level 3 Cache, 9 MB per core 9140N processor
- 1.4 GHz with 12 MB Level 3 Cache, 6 MB per core processor
- 1.4 GHz with 12 MB Level 3 Cache, 6 MB per core 9120N processor

All processors support:

- Level 2 Cache: 1 MB Instruction/256 KB Data per core
 - Level 1 Cache: 32 KB
 - Four threads (two threads per core)
 - Single bit cache error correction
 - 50 bit physical addressing
 - 64 bit virtual addressing
 - 4 GB maximum page size
-

Processor Configuration Rules

- Processors can be installed one at a time
- Processors must be installed in the following sequence: 0, 1, 2, and 3
- Different speed and different cache size processors cannot be mixed in the same system

Memory Configuration The HP Integrity rx6600 supports double data rate (DDR2) synchronous dynamic random access memory (SDRAM) DIMMs with ECC and double chip spare protection. The HP Integrity rx6600 can be ordered with one of the following two memory carrier boards:

- AD126A-Supports from 2 GB minimum to 96 GB maximum memory; 8.5 GB/s memory bandwidth. The AD126A can be replaced with the AD127A to increase maximum memory beyond 96-GB and to a maximum of 192-GB, or to increase memory bandwidth to 17.0 GB/s. Please note, there is no return credit for the AD126A.
- AD127A-Supports from 2 GB minimum to 192 GB maximum memory; 17.0 GB/s memory bandwidth.

Memory Loading Rules

- Memory must be installed in groups of four DIMMs, also known as quads
 - Each quad must consist of equal density DIMMs
 - Memory can be ordered in quads of 2 GB (4×512MB), 4 GB (4×1GB), 8 GB (4×2GB), or 16 GB (4×4GB)
 - Minimum memory is 2 GB (4×512MB)
 - Maximum memory is 192 GB, using twelve 16 GB memory quads in memory carrier option AD127A
 - Memory must be loaded in the order depicted on the memory carrier board.
 - Arrange DIMMs so that the quads with the largest capacity are in the lowest numbered slots.
-

Configuration

- For best performance, all DIMM slots on both memory carrier boards should be populated with the same size DIMM.

Memory Options

Description	Product Number
2-GB chip spare PC2-4200 ECC x4 single rank Registered DDR2 SDRAM memory quad (4×512MB DIMMs)	AB563A
4-GB chip spare PC2-4200 ECC x4 single rank Registered DDR2 SDRAM memory quad (4×1 GB DIMMs)	AB564A
8-GB chip spare PC2-4200 ECC x4 single rank Registered DDR2 SDRAM memory quad (4×2GB DIMMs)	AB565A
16-GB chip spare PC2-4200 ECC x4 single rank Registered DDR2 SDRAM memory quad (4×4GB DIMMs)	AB566A

Server Form Factor and Rack Configuration

The HP Integrity rx6600 is a 7U rack optimized server. It is supported in HP 10000 G2 series cabinets. For factory integration order AD053A with 0D1 feature code. Sliding mounts and a cable management arm will be installed with the server in a factory integrated rack.

The HP Integrity rx6600 can be installed in the field with the Field Rack Kit (AD053A with B01 feature code). This field kit contains the slide mounts, cable management arm, and all other hardware needed to mount an rx6600 into a 19 inch cabinet.

Refer to the 10000 G2 Series Rack Best Practices Guide for information on rack deployment, stabilization and transportation. Go to <http://www.hp.com/go/rackandpower> for more information.

The rx6600 is also available in a stand-alone, pedestal form factor (AD308A). Kit will be shipped in a separate box for field installation only.

I/O Architecture

The HP Integrity rx6600 supports two I/O backplane options in order to provide maximum flexibility, I/O card availability, performance, scalability and reliability. The two options are a PCI-X 2.0 Backplane (AD296A Option Code 100) or a PCI-Express Backplane option (AD296A OptionCode 200). Only one backplane per system is supported.

PCI-X 2.0 Backplane:

This backplane provides ten PCI X I/O slots, two of which are reserved for Core I/O cards, and eight of which are available for I/O card expansion. The Core I/O slots will always be filled with either an HP PCI X 8 Internal Port Serial Attached SCSI (SAS) host bus adapter (for HP UX and OVMS systems) or an HP PCI X Smart Array (P600) 8 Internal Port Serial Attached SCSI (SAS) card (for Windows and Linux systems) (slot #1) and a PCI X dual port 10/100/1000Base TX LAN adapter (slot #2).

Each port of a Serial Attached SCSI card can be connected to a Serial Attached SCSI hard disk drive. When more than eight hard disk drives are required, a second HP PCI-X 8 port SAS card must be ordered. This second SAS card will be installed in the second core I/O slot, and the PCI-X dual port 10/100/1000Base TX LAN adapter will be moved out to a standard I/O slot. Note that when the LAN adapter is moved out to a standard I/O slot, Wake On LAN is not supported.

HP-UX and OpenVMS based systems with PCI-X 2.0 Backplane:

Must choose the HP PCI-X 8 Internal Port Serial Attached SCSI host bus adapter for Core I/O controller (AB036B Option Code 006 or Option Code 106). If factory configured RAID is not desired, select Option Code 006. If factory configured RAID-1 is desired, select Option Code 106. RAID-1 only is supported on the HP PCI-X 8 Internal Port SAS host bus adapter. When selecting Option Code 106, a minimum of 2 HDD's of the same size and speed are required. A maximum of two internal RAID 1 volumes (2×2 HDDs) and a disk for global hot spare, for a maximum of five disks in RAIDed arrays is supported. The additional three drives (of the maximum of eight drives supported on the controller) can be accessed normally, but not configured for RAID. When from 9 to 16 HDD's are ordered, a second SAS Controller is required to support disks 9 through 16. The second controller cannot be factory configured for RAID (unless it is done through Factory Express). For customer/field configured RAID arrays, the same limitations (two RAID 1 arrays and one global hot spare) exist. The additional three HDDs (14 through 16) can be accessed normally, but not configured for RAID. Please see rx6600 Ordering Guide for factory configuration details. Please note that MirrorDisk/UX is available

Configuration

for SW Mirroring on all HDDs in HP-UX based systems and HP Volume Shadowing Level 1 for HDDs in OpenVMS-based systems.

Windows and Linux based systems with PCI-X 2.0 Backplane:

Must choose the HP PCI-X 8 port Smart Array (P600) Serial Attached SCSI (SAS) controller for Core I/O controller (AB036B Option 100, or Option 500, or Option 510). Option 100 provides for factory configuration of RAID-1 (requires a minimum of 2 HDDs). Option 500 provides for factory configuration of RAID-5 (requires a minimum of 3 HDDs). Option 510 provides for factory configuration of RAID-6 (requires a minimum of 4 HDDs). All HDDs must be the same size and speed. When from 9 to 16 HDDs are ordered, a second SAS Controller is required to support disks 9 through 16. The second controller cannot be factory configured for RAID (unless it is done through Factory Express) . Please see rx6600 Ordering Guide for details.

Remaining Eight (non-Core I/O) slots:

The two slots (#3 and #4) next to the Core I/O slots have their own dedicated 64 bit 266 MHz PCI X bus and their own independent 2.1 GB/s I/O channel. These slots should be used for high performance PCI X cards, such as clustering interconnects or multi port storage adapters. The next two slots (slots #5 and #6) each have their own dedicated 64 bit 133 MHz PCI X bus and their own independent 1.1 GB/s I/O channel. The independent buses and I/O channels provide improved performance and error containment. Independence protects each I/O card from bus hangs or extended latencies due to the failure or high bandwidth demands of other I/O cards. Independence also ensures that each I/O card can achieve maximum throughput.

The remaining four slots (#7 through #10) share two 64 bit 66 MHz PCI X buses, with two slots allocated to each bus. Each pair of slots shares a 0.5 GB/s I/O channel.

NOTE: Hot plug operations are not supported with the Linux or OpenVMS operating systems or in the core I/O slots with any operating system.

All I/O slots are keyed for I/O cards with 3.3V signaling. Cards that use 5V signaling are not supported in the HP Integrity rx6600.

PCI-Express Backplane:

This backplane also provides ten I/O slots. There are two PCI X Core I/O slots; one PCI X Core I/O slot will always have a PCI X dual port 10/100/1000Base TX LAN adapter (slot #2), unless a second storage controller is required, in which case the second controller is configured in slot #2 and the LAN card is moved out to public slot #10, and one PCI X Core I/O slot is provided in the case that the HP PCI X 8 Internal Port Serial Attached SCSI (SAS) host bus adapter is chosen when ordering an HP UX or OpenVMS based system, or if an HP PCI X Smart Array (P600) 8 Internal Port Serial Attached SCSI (SAS) card is chosen (slot #1) when ordering a Windows or Linux based system. If a PCI Express 8 port Smart Array (P400, supports only internal connection to SAS disks) Serial Attached SCSI controller (supported with HP UX, OpenVMS, Windows, and Linux) is chosen, or if a PCI Express 16 port (8 internal ports and 8 external ports) Smart Array (P800) Serial Attached SCSI controller (for Windows and Linux only, also supports connection to external SAS disks) is chosen, the PCI X Core I/O slot remains empty and the PCI Express controller is installed in slot #3.

Each port of a Serial Attached SCSI card can be connected to a Serial Attached SCSI hard disk drive. When more than eight hard disk drives are required, a second 8 port Serial Attached SCSI card must be ordered. If a PCI-X card is chosen, it will be installed in the reserved PCI-X core I/O slot. If a PCI-Express card is chosen, it will be installed in slot #4.

HP-UX and OpenVMS based systems with PCI-Express Backplane:

These systems have the two choices for Core I/O controller; the HP PCI-X 8 Internal Port Serial Attached SCSI host bus adapter or the HP PCI-Express 8 Internal Port Smart Array (P400) Serial Attached SCSI controller.

1. HP PCI-X 8 Internal Port Serial Attached SCSI host bus adapter (AB036B Option Code 006 or Option Code 106). If factory configured RAID is not desired, select Option Code 006. If factory configured RAID-1 is desired, select Option Code 106. RAID-1 only is supported on the HP PCI-X 8 Internal Port SAS host bus adapter. When selecting Option Code 106, a minimum of 2 HDD's of the same size and speed are required. A maximum of two internal RAID 1 volumes (2x2 HDDs) and a disk for global hot spare, for a maximum of five disks in RAIDed arrays is supported. The additional three drives (of the maximum of eight drives supported on the controller) can be accessed normally, but not configured for RAID. When from 9 to 16 HDD's are ordered, a second SAS Controller is required to support disks 9 through 16. The second controller cannot be factory configured for RAID (unless it is done through Factory Express). For customer/field configured RAID arrays, the same

Configuration

limitations (two RAID 1 arrays and one global hotspare) exist. The additional three HDDs (14 through 16) can be accessed normally, but not configured for RAID. Please see rx6600 Ordering Guide for factory configuration details. Please note that MirrorDisk/UX is available for SW Mirroring on all HDDs in HP-UX based systems and HP Volume Shadowing Level 1 for HDDs in OpenVMS-based systems.

2. PCI-Express 8-port Smart Array (P400) Serial Attached SCSI Controller (AB036B Option 130, or Option 530, or Option 540). Requires PCI-Express Backplane (AD296A Option 200). Option 130 provides for factory configuration of RAID-1 (requires a minimum of 2 HDDs). Option 530 provides for factory configuration of RAID-5 (requires a minimum of 3 HDDs). Option 540 provides for factory configuration of RAID-6 (requires a minimum of 4 HDDs). All HDDs must be the same size and speed. When from 9 to 16 HDDs are ordered, a second SAS Controller is required to support disks 9 through 16. The second controller cannot be factory configured for RAID (unless it is done through Factory Express) . Please see rx6600 Ordering Guide for details.

Note: MirrorDisk/UX is available for SW Mirroring on all HDDs in HP UX based systems and HP Volume Shadowing Level 1 for HDDs in OpenVMS-based systems.

Windows and Linux based systems with PCI-Express Backplane:

These system have three choices for Core I/O controller; the PCI-X 8 Internal Port Smart Array (P600) Serial Attached SCSI controller, or the PCI-Express 8 Internal Port Smart Array (P400) Serial Attached SCSI controller, or the PCI-Express 16-port (8 Internal/8 External) Smart Array (P800) Serial Attached SCSI controller.

1. HP PCI-X 8 port Smart Array (P600) Serial Attached SCSI controller (AB036B Option 100, or Option 500, or Option 510). Option 100 provides for factory configuration of RAID-1 (requires a minimum of 2 HDDs). Option 500 provides for factory configuration of RAID-5 (requires a minimum of 3 HDDs). Option 510 provides for factory configuration of RAID-6 (requires a minimum of 4 HDDs). All HDDs must be the same size and speed. When from 9 to 16 HDDs are ordered, a second SAS Controller is required to support disks 9 through 16. The second controller cannot be factory configured for RAID (unless it is done through Factory Express) . Please see rx6600 Ordering Guide for details.
2. PCI-Express 8-port Smart Array (P400) Serial Attached SCSI Controller (AB036B Option 130, or Option 530, or Option 540). Requires PCI-Express Backplane (AD296A Option 200). Option 130 provides for factory configuration of RAID-1 (requires a minimum of 2 HDDs). Option 530 provides for factory configuration of RAID-5 (requires a minimum of 3 HDDs). Option 540 provides for factory configuration of RAID-6 (requires a minimum of 4 HDDs). All HDDs must be the same size and speed. When from 9 to 16 HDDs are ordered, a second SAS Controller is required to support disks 9 through 16. The second controller cannot be factory configured for RAID (unless it is done through Factory Express) . Please see rx6600 Ordering Guide for details.
3. PCI-Express 16-port Smart Array (P800) Serial Attached SCSI Controller (AB036B Option 150, or Option 550, or Option 560). Requires PCI-Express Backplane (AD296A Option 200). Option 150 provides for factory configuration of RAID-1 (requires a minimum of 2 HDDs). Option 550 provides for factory configuration of RAID-5 (requires a minimum of 3 HDDs). Option 560 provides for factory configuration of RAID-6 (requires a minimum of 4 HDDs). All HDDs must be the same size and speed. When from 9 to 16 HDDs are ordered, a second SAS Controller is required to support disks 9 through 16. The second controller cannot be factory configured for RAID (unless it is done through Factory Express) . Please see rx6600 Ordering Guide for details.

Remaining Eight (non-Core I/O) slots:

The two slots (#3 and #4) next to the Core I/O slots share a PCI-Express x8 1.3-GB/s I/O channel. The next two slots (slots #5 and #6) each have their own PCI-Express x8 2.6-GB/s I/O channel. The independent I/O channels provide improved performance and error containment. Independence protects each I/O card from bus hangs or extended latencies due to the failure or high bandwidth demands of other I/O cards. Independence also ensures that each I/O card can achieve maximum throughput. These slots should be used for high performance PCI X cards, such as clustering interconnects or multi port storage adapters.

The remaining four slots (#7 through #10) are PCI-X slots. Slots #7 and #8 each have their own dedicated 64 bit 133 MHz PCI-X channel; slot #7 is 1.1 GB/s and slot #8 is 0.5 GB/s. Slots #9 and #10 share a 64-bit 66-MHz PCI-X 0.5 GB/s I/O channel.

Note: Hot plug operations are not supported with the Linux or OpenVMS operating systems or in the PCI X Core I/O slots with any operating system. Hot plug operations are not supported for any operating system in slots #3 or #4

Configuration

All I/O slots are keyed for I/O cards with 3.3V signaling. Cards that use 5V signaling are not supported in the HP Integrity rx6600.

Supported I/O Cards

Supported HP-UX I/O Cards

I/O Card	Product Number	PCIe/PCI-X	Boot Support	Connector Type(s)	Maximum Cards PCI-X Backplane	Maximum Cards PCI-Express Backplane	Special Notes
Mass Storage Host Bus Adapters							
PCI 2 channel Ultra320 SCSI	A7173A	PCI-X	Yes	VHDCI	8	4	
PCI-X 2 channel Smart Array 6402 Ultra320 ¹	A9890A	PCI-X	Yes	VHDCI	6	2	Requires minimum of 512-MB of memory and full length slot
PCI-X 4 channel Smart Array 6404 Ultra320 ¹	A9891A	PCI-X	Yes	VHDCI	6	1	Requires minimum of 512-MB of memory and full length slot
PCI-X 266 MHz 1 channel 4-Gb/s Fibre Channel	AB378B	PCI-X	Yes	LC	8	4	
PCI-X 266 MHz 2 channel 4-Gb/s Fibre Channel	AB379B	PCI-X	Yes	LC	8	4	
PCIe Smart Array P800	AD335A	PCIe	Yes	Mini SAS	0	4	
PCIe 2-port 4-Gb/s Fibre Channel	AD300A	PCIe	Yes	LC	0	2	
HP PCIe 1-port 4-Gb/s Fibre Channel HBA	AD299A	PCIe	No	LC	0	2	
HP PCIe 2-port 4-Gb/s Fibre Channel HBA	AD355A	PCIe	No	LC	0	2	
PCIe 4Gb Fibre Channel / GbE-T HBA combo	AD221A	PCIe	Yes		0	4	
PCIe 2-port 4Gb Fibre Channel / 2-port GbE-T HBA combo	AD222A	PCIe	Yes		0	4	
PCIe 2-port 4Gb Fibre Channel / 2-port GbE-SX HBA combo	AD393A	PCIe	Yes		0	4	
Local Area Network (LAN) Adapters							
PCI-X 1-port 1000Base-T (gigabit copper)	AD331A	PCI-X	No	RJ-45	8	4	
PCI-X 1-port 1000Base-SX (gigabit fiber)	AD332A	PCI-X	No	LC	8	4	
PCI-X 2-port 1000Base-T	A7012A	PCI-X	Yes	RJ-45	8	4	
PCI-X 2-port 1000Base-SX	A7011A	PCI-X	Yes	Duplex SC	8	4	

Configuration

PCI X 2-port 4x Fabric (HPC) Adapter ¹	AB286C	PCI-X	No	4x Infiniband Copper	8	4	For maximum performance, card should not be installed in a shared slot. Requires a minimum of 512-MB memory.
PCI-X 4-port 1000Base-T Gbit Adapter	AB545A	PCI-X	Yes	RJ-45	8	4	
PCIe 4-port HP NC364T Gbit Adapter	AD339A	PCIe	Yes		0	4	
PCI-X 1-Port 10GbE	AB287A	PCI-X	Yes	DuplexLC	4	2	For best performance, recommend at least one processor core per card installed in the system. Each card requires 512MB of memory. Card cannot be installed in a shared slot.
PCI-X 266-MHz 1-port 10GbE	AD385A	PCI X	Yes	Duplex LC	4	2	For best performance, recommend at least one processor core per card installed in the system. Each card requires 512 MB of memory. Card cannot be installed in a shared slot.
PCIe 2-port 4x Fabric (PHC) Adapter	AD313A	PCIe	No	4x Infiniband Copper	0	4	Supported with HP-UX 11i v2 Only
PCIe 2-port 4X DDR Fast IB HCA	AH304A	PCIe	No		0	4	
HP PCIe 2-port 1000Base-T card	AD337A	PCIe	Yes	RJ-45	0	4	
HP PCIe 2-port 1000Base-SX card	AD338A	PCIe	Yes	Duplex SC	0	4	
HP PCIe 2-port 1000Base-T T1 card	AD380A	PCIe	Yes	RJ-45	0	4	
HP PCIe 2-port 1000Base-SX T1 card	AD381A	PCIe	Yes	Duplex SC	0	4	
HP PCI-e 10GbE SR card	AD386A	PCIe	Yes		0	4	
PCI 1000Base-T Gigabit Ethernet Adpt	A6825A	PCI-X	No	RJ-45	8	4	
PCI 1000Base-SX Gigabit Ethernet Adpt	A6847A	PCI-X	No	Duplex SC	8	4	
Multi-Function Cards (Mass Storage/LAN)							
PCI-X 2Gb Fibre Channel / 1000BaseSX	A9782A	PCI-X	Yes	LC	8	4	For maximum performance, card should not be installed in a shared slot.

Configuration

PCI-X 2Gb Fibre Channel / 1000BaseTX	A9784A	PCI-X	Yes	1 LC, 1 RJ-45	8	4	For maximum performance, card should not be installed in a shared slot.
HP PCI-X 1-port 4-GB Fibre Channel/1-port 1000Base-T Adapter	AD193A	PCI-X	Yes	1 LC, 1 RJ-45	8	4	
PCI-X 2-port 2-Gb Fibre Channel/2-port 1-Gb Ethernet Adapter	AB465A	PCI-X	Yes	2LC, 2 RJ-45	8	4	
HP PCI-X 2-port 4-GB Fibre Channel/2-port 1000Base-T Adapter	AD194A	PCI-X	Yes	2LC, 2 RJ-45	8	4	
PCI-X 2-port 1000BT/2-port U320 SCSI Multifunction Adapter	AB290A	PCI-X	Yes	SCSI - LVD/SELAN - RJ-45	6	2	Card cannot be in a shared slot with an AB551A graphics card. Requires full length slot.
Wide Area Network (WAN) Adapters							
2 port Programmable Serial Interface (PSI) X.25/Frame Relay/SDLC	J3525A	PCI-X	No	RS-530, RS-232, V.35, RS-449 or X.21	8	4	
Additional Interface Cards							
HP OpenVMS, HP-UX PCI Graphics Card	AB551A	PCI-X	No	VGA	2	2	
PCI 8-port Serial MUX Adapter	AD278A	PCI-X	No		8	4	
PCI 64-port Serial MUX Adapter	AD279A	PCI-X	No		8	4	
16-port RS-232 RJ45 Port Module	AD280A	PCI-X	No	4 per AD279A	N/A	N/A	AD280A #001 Port Module Power Supply, required on Port Module (3) and Port Module (4) connected to an AD279A 64-port MUX adapter.
16-port RS-232 DB-25 Port Module	AD281A	PCI-X	No	4 per AD279A	N/A		AD281A #001 Port Module Power Supply, required on Port Module (3) and Port Module (4) connected to an AD279A 64-port MUX adapter.

Supported OpenVMS I/O Cards

Configuration

I/O Card	Product Number	PCIe/ PCI-X	Boot Support	Connector Type(s)	Maximum Cards PCI-X Backplane	Maximum Cards PCI- Express Backplane	Special Notes
Mass Storage Host Bus Adapters							
PCI 2 channel Ultra320 SCSI	A7173A	PCI-X	Yes	VHDCI	4	4	No On Line Add and Replace support.
PCI-X 2 channel Smart Array 6402 Ultra320 ¹	A9890A	PCI-X	Yes	VHDCI	2	2	Requires minimum of 512-MB of memory and full length slot
PCI-X 4 channel Smart Array 6404 Ultra320 ¹	A9891A	PCI-X	Yes	VHDCI	1	1	Requires minimum of 512-MB of memory and full length slot
PCI-X 266 MHz 1 channel 4 Gb/s Fibre Channel	AB378B	PCI-X	Yes	LC	8	4	
PCI-X 266 MHz 2 channel 4 Gb/s Fibre Channel	AB379B	PCI-X	Yes	LC	8	4	
PCIe Smart Array P800	AD335A	PCIe	Yes	Mini SAS	0	4	
PCIe 2-port 4-Gb/s Fibre Channel	AD300A	PCIe	Yes	LC	0	4	
Local Area Network (LAN) Adapters							
PCI-X 1 port 1000Base-T (gigabit copper)	AD331A	PCI-X	No	RJ-45	8	4	
PCI-X 1 port 1000Base-SX (gigabit fiber)	AD332A	PCI-X	No	LC	8	4	
PCI X 1 Port 10GbE	AB287A	PCI-X	No	Duplex LC	2	2	
PCI-X 2-port 1000Base-T	A7012A	PCI-X	No	RJ-45	8	4	
PCI-X 2-port 1000Base-SX	A7011A	PCI-X	No	Duplex SC	8	4	
PCI-X 4-port 1000Base-T Gbit Adapter	AB545A	PCI-X	No	RJ-45	3	3	
PCIe 4-port HP NC364T Gbit Adapter	AD339A	PCIe	Yes		0	4	
Multi-Function Cards (Mass Storage/LAN)							
PCI-X 2Gb Fibre Channel / 1000BaseSX	A9782A	PCI-X	Yes	LC	4	4	For maximum performance, card should not be installed in a shared slot.
PCI-X 2Gb Fibre Channel / 1000BaseTX	A9784A	PCI-X	Yes	1 LC, 1 RJ-45	4	4	For maximum performance, card should not be installed in a shared slot.
HP PCI-X 1-port 4-GB Fibre Channel/1-port 1000Base-T Adapter	AD193A	PCI-X	Yes	1 LC, 1 RJ 45	2	2	
PCI-X 2-port 2-Gb Fibre Channel/2-port 1-Gb Ethernet Adapter	AB465A	PCI-X	Yes	2 RJ-45	2	2	

Configuration

HP PCI-X 2-port 4-GB Fibre Channel/2-port 1000Base-T Adapter	AD194A	PCI-X	Yes	2LC, 2 RJ-45	2	2	
PCI-X 2-port 1000BT/2-port U320 SCSI Multifunction Adapter	AB290A	PCI-X	Yes	SCSI - LVD/SE LAN - RJ-45	2	2	Requires full length slot.
Additional Interface Cards							
HP OpenVMS, HP UX PCI Graphics Card	AB551A	PCI	No	VGA	4	3	Field installation only. On PCI-X backplane can be installed in slots 5, 6, 7, 9. On PCI-e backplane, can be installed in slots 7, 8, 9.. Slot 9 can be shared with core LAN in slot 10.

Supported Windows I/O Cards

I/O Card	Product Number	PCIe/PCI-X	Boot Support	Connector Type(s)	Maximum Cards PCI-X Backplane	Maximum Cards PCI-Express Backplane	Special Notes
Mass Storage Host Bus Adapters							
PCI 2 channel Ultra320 SCSI	A7173A	PCI-X	Yes	VHDCI	2	2	
PCI-X Smart Array P600 Serial Attached SCSI (SAS) Controller (for external storage only)	337972-B21	PCI-X	Yes	SFF8470	6	4	A maximum of (4) may be ordered with #0D1, the remaining (2) must be ordered without #0D1
512 MB cache memory upgrade for SA640x and SA P600 controller	372538-B21	PCI-X	N/A	N/A	N/A	N/A	
PCI-X 266 MHz 2 channel 4 Gb/s Fibre Channel	AB379A	PCI-X	Yes	LC	6	4	
PCI-X 266-MHz 2-channel 4-Gb/s Fibre Channel	AB379B	PCI-X	Yes	LC	6	4	Replaces AB379A
PCI-X 266 MHz 1 channel 4 Gb/s Fibre Channel	AD167A	PCI-X	Yes	LC	6	4	
PCI-X 266 MHz 2 channel 4 Gb/s Fibre Channel	AD168A	PCI-X	Yes	LC	6	4	
PCI-X 266 MHz 1 channel 4 Gb/s Fibre Channel	AB429A	PCIe	Yes	LC	6	4	
PCIe Smart Array P800	AD335A	PCIe	Yes	Mini SAS	0	4	
PCIe Smart Array P500	AH226A	PCIe	Yes	Mini SAS	0	4	
PCIe 2-port 4-Gb/s Fibre Channel	AD300A	PCIe	Yes	LC	0	4	
PCIe 1-port 4-Gb/s Fibre Channel	AE311A	PCIe	Yes	LC	0	4	

Configuration

PCIe 1-port 4-Gb/s Emulex Fibre Channel	A8002A	PCIe	Yes	LC	0	4	
PCIe 2-port 4-Gb/s Emulex Fibre Channel	A8003A	PCIe	Yes	LC	0	4	
Local Area Network (LAN) Adapters							
PCI 2 port Windows/Linux 1000Base SX	A9899A	PCI-X	No	LC	6	4	No On Line Add and Replace support.
PCI 2 port Windows/Linux 1000Base-TX	A9900A	PCI-X	No	RJ-45	6	4	No On Line Add and Replace support.
HP PCIe 2-port 1000Base-T card	AD337A	PCIe	Yes	RJ-45	0	4	
HP PCIe 2-port 1000Base-SX card	AD338A	PCIe	Yes	Duplex SC	0	4	
HP PCIe 2-port 1000Base-T T1 card	AD380A	PCIe	Yes	RJ-45	0	4	
HP PCIe 2-port 1000Base-SX T1 card	AD381A	PCIe	Yes	Duplex SC	0	4	
PCI X 1 port 10 GbE	AD144A	PCI X	Yes	Duplex LC	4	4	Each card requires 512 MB of memory. Card cannot be installed in a shared slot.

Supported Linux (RHEL 4 U4 and SLES 10) I/O Cards

I/O Card	Product Number	PCIe/ PCI-X	Boot Support	Connector Type(s)	Maximum Cards PCI-X Backplane	Maximum Cards PCI-Express Backplane	Special Notes
Mass Storage Host Bus Adapters							
PCI 2 channel Ultra320 SCSI	A7173A	PCI-X	Yes	VHDCI	4	4	No On Line Add and Replace support.
PCI X Smart Array P600 Serial Attached SCSI (SAS) Controller (for external storage only)	337972-B21	PCI-X	Yes	SFF8470	4	4	
512 MB cache memory upgrade for SA640x and SA P600 controller	372538-B21	PCI-X	N/A	N/A	N/A	N/A	
PCI X 266 MHz 2 channel 4 Gb/s Fibre Channel	AB379B	PCI-X	Yes	LC	4	2	Qlogic and Emulex HBAs are not supported in the same server
PCI X 266 MHz 1 channel 4 Gb/s Fibre Channel	AD167A	PCI-X	Yes	LC	6	0	Qlogic and Emulex HBAs are not supported in the same server. No On Line Add and Replace support.

Configuration

PCI X 266 MHz 2 channel 4 Gb/s Fibre Channel	AD168A	PCI-X	Yes	LC	6	0	Qlogic and Emulex HBAs are not supported in the same server. No On Line Add and Replace support.
PCI X 266 MHz 1 channel 4 Gb/s Fibre Channel	AB429A	PCI-X	Yes	LC	4	2	Qlogic and Emulex HBAs are not supported in the same server
PCIe 2-port 4-Gb/s Fibre Channel	AD300A	PCIe	Yes	LC	0	4	
PCIe 1-port 4-Gb/s Fibre Channel	AE311A	PCIe	No	LC	0	4	
PCIe Smart Array P800	AD335A	PCIe	No	Mini SAS	0	4	
PCIe 1 port 4 Gb/s Emulex Fibre Channel	A8002A	PCIe	Yes	LC	0	4	
PCIe 2 port 4 Gb/s Emulex Fibre Channel	A8003A	PCIe	Yes	LC	0	4	
PCI X 266 MHz 2 channel 4 Gb/s Fibre Channel	AB379B	PCI X	Yes	LC	4	2	Replaces AB379A
Local Area Network (LAN) Adapters							
PCI 2-port Windows/Linux 1000Base-SX	A9899A	PCI-X	No	LC	8	4	No On Line Add and Replace support.
PCI 2-port Windows/Linux 1000Base-TX	A9900A	PCI-X	No	RJ-45	8	4	No On Line Add and Replace support.
PCI-X 1 port 10 GbE	AD144A	PCI-X	Yes	Duplex LC	2	2	Each card requires 512MB of memory. Card cannot be installed in a shared slot.
PCIe 1 port 4 Gb/s Fibre Channel	AE311A	PCIe	Yes	LC	0	4	

¹ Required for Windows, Linux and OpenVMS. Optional for HP UX. Maximum 1 supported.

Support Internal Storage Devices	Product Number
Device	
Internal Hard Drives	
36-GB 15K RPM Hot Plug Serial Attached SCSI (SAS) 2.5-inch Drive	AD378A
72-GB 10K RPM Hot Plug Serial Attached SCSI (SAS) 2.5-inch Drive	AD141A
72-GB 15K RPM Hot Plug Serial Attached SCSI (SAS) 2.5-inch Drive	AD379A
146-GB 10K RPM Hot Plug Serial Attached SCSI (SAS) 2.5-inch Drive	AD333A
Removable Media*	
DVD ROM Drive	AD142A
DVD+RW Drive** (Not supported on HP-UX at this time)	AD143A
*Required for Windows, Linux and OpenVMS. Optional for HP UX. Maximum 1 supported.	
**Third party software (not included with AD143A) is required to support DVD write with Windows on AD143A.	

Configuration

Integrated Multi-function Core I/O The integrated multifunction I/O provides core I/O functionality and includes the integrated management processor, which provides remote management and high availability monitoring capabilities.

- PCI-X Dual port 10/100/1000Base T LAN with RJ 45 connector-Supports LAN boot for operating system installation.
- The base system offerings require choice of at least one HP 8 Port Serial Attached SCSI (SAS) controller. Choices vary depending on choice of I/O backplane (PCI-X 2.0 backplane or PCI-Express backplane) and choice of operating system. Please see Table 2.9.2 HP Integrity rx6600 Features - Standard System Features earlier in this chapter, or the section I/O Architecture beginning on page 2-230, and the rx6600 Ordering Guide.
- Factory configured RAID is available with all Core I/O controllers. Please see Table 2.9.2 HP Integrity rx6600 Features - Standard System Features earlier in this chapter, or the section I/O Architecture beginning on page 2-230, and the rx6600 Ordering Guide. When configuring for RAID, all HDD's in the system must be the same size and speed.

Integrated Integrity iLO 2 Management Processor Functionality

- Dedicated 10/100BaseTX LAN port for LAN console and embedded web console access.
- One RS 232 serial port for local console.
- Password protected console ports.
- Console mirroring between all local, modem, LAN, and web consoles.
- Remote power up and power down control.
- Configurable remote access control.
- Event notification to system console-Provides connectivity, information, and support for HP UX tools (such as STM and EMS) to notify by email, pager and/or HP response centers.
- Interface to system monitoring and diagnostic hardware via an internal IC bus.
- Secure Sockets Layer security on web console.
- Support for Integrated Lights Out version 2 (iLO v2) Advanced Pack activation key and license (AD301A). Firmware license installs on the integrated Management Processor Card. Integrated Lights Out (iLO) Advanced Pack provides additional remote management capabilities, including integrated remote console and virtual CD/DVD drive, and LDAP directory services, SSH security, and Group Actions with HP Systems Insight Manager (SIM).
- Basic graphic capabilities are available as an optional upgrade. The upgrade provides these capabilities via the Radeon 7000 2D graphics chip and 16 MB memory, which resides on the integrated Integrity iLO 2 management processor card. VGA port is provided on rear of the system. Supported resolutions and refresh rates include:

Operating System	Minimum Resolution	Refresh Rate	Maximum Resolution	Refresh Rate
HP-UX	1024x768	75 Hz	1920x1200	75 Hz
Linux	1024x768	75 Hz	1920x1200	75 Hz
Windows	640x480	75 Hz	1600x1200	75 Hz
OpenVMS	640x480	60 Hz	1920x1200	75 Hz

Configuration

System Console Configurations

The HP Integrity rx6600's integrated Management Processor Card provides six methods for console connections.

- SSL secured Web console accessible through the 10/100Base T management LAN
- Standard telnet connections accessible through the 10/100Base T management LAN
- Local VT100 or hpterm terminal, or VT100 or hpterm emulator via local RS 232 serial connection
- Remote VT100 or hpterm terminal, or VT100 or hpterm emulator via external modem
- VGA graphics console using the upgrade to the VGA port. This upgrade is required for Windows systems and optional for HP UX and Linux systems. Keyboard and mouse connections are provided by USB. OpenVMS doesn't support VGA console for boot operations, but supports the VGA device for graphics use after boot.
- Integrated Remote Console (virtual KVM) through the iLO 2 Advanced Pack (Windows systems only).

Internal Disk and Media Drives

- The HP Integrity rx6600 supports up to sixteen internal Serial Attached SCSI (SAS) 2.5 inch hot plug disk drives.
- A PCI-X or PCI-Express 8 port host bus adapter provides 8 ports, 1 port per SAS disk, for point to point connection from the adapter to the disk. This means that each disk has its own 3 GB link. A second HP 8 Internal port host bus adapter must be ordered to support disks 9 through 16.
- Factory configured RAID is available with all Core I/O controllers. Please see Table 2.9.2 HP Integrity rx6600 Features - Standard System Features earlier in this chapter, or the section I/O Architecture beginning on page 2-230, and the rx6600 Ordering Guide. When configuring for RAID, all HDD's in the system must be the same size and speed.
- Cables required to connect the internal disk drives to the host bus adapter are shipped with the system; no need to order separately.
- 36-GB 10K and 15K, 72-GB 10K and 15K, and 146-GB Serial Attached SCSI (SAS) disks are supported. 300 GB 10K SAS disks will be supported on all operating systems in a future release.
- Optical media drives include a DVD ROM (AD142A) and DVD+RW (AD143A). A DVD drive is required for all OpenVMS, Linux, and Windows configurations. Third party software (not included with the AD143A) is required to support DVD write with Windows on AD143A. Please note that that the AD143A is not supported on HP UX based systems.

HP Integrity rx6600 Trusted Platform Module

The rx6600 has an accessory option for an embedded security chip - the Trusted Platform Module (TPM) - product number AB404A. HP-UX Trusted Computing Services (HP-UX TCS) provides software support for the TPM when running HP-UX 11i v2. By providing a low-cost embedded security chip option (known as a Trusted Platform Module) in its zx2-based Integrity servers (rx2660, rx3600, and rx6600), HP has established a foundation for strong protection of sensitive information - including cryptographic keys. Built around industry standards, the Trusted Platform Module (TPM) provides a basis for key storage by securely generating and storing cryptographic keys. HP-UX 11i TCS takes this a step further by providing the necessary infrastructure for managing the TPM, as well as integrating it into select features such as HP-UX Encrypted Volumes and File Systems (EVFS).

Using HP-UX TCS with EVFS:

Using HP-UX TCS to make the unattended boot capability of EVFS more secure is an important example of how HP-UX TCS can be integrated with other applications to enhance security. For more information see the "Protecting EVFS Keys with HP-UX TCS" chapter in the "HP-UX Trusted Computing Services Administrators Guide" available in the HP-UX Trusted Computing Services section at:

<http://docs.hp.com/en/internet.html>

Configuration

Please note that HP-UX 11iTCS requires:

- (1) An HP zx2-based Integrity server (rx2660, rx3600, or rx6600) with a TPM installed, running HP-UX 11i v2 September 2006 release or later
- (2) Installation of kernel patch PHKL_35428

To download TCS and EVFS, please see the HP-UX Software Depot web page at: <http://software.hp.com>

HP Integrity rx6600 Power Subsystem The HP Integrity rx6600 provides a high level of integrated power protection:

- N+1 redundant hot swap power supplies
- N+1 redundant AC power input protection with electrical phase isolation
- Power monitoring and control

The HP Integrity rx6600 supports a second hot swap power supply for N+1 protection. One supply is shipped as a standard part of every system and is required for correct operation. The hot swap design allows for the online replacement of a power supply when N+1=2 supplies are configured in the server.

The HP Integrity rx6600 provides an independent power input receptacle for each power supply. The independent design provides protection against losing the connection from a power cord or breaker. The HP Integrity rx6600 power cords should always be plugged into separate breakers when possible.

Technical Specifications

Server model number rx6600

Server product numbers	<p>Four processor/eight core capable HP Integrity rx6600 base system with one dual core processor module AB464A</p> <p>Configure with one 1.4 GHz/12 MB dual core processor module Option 140</p> <p>Configure with one 1.6 GHz/18 MB dual core processor module Option 160</p> <p>Configure with one 1.6 GHz/24 MB dual core processor module Option 180</p> <p>Configure with one 1.4 GHz/12 MB dual core 9120N processor module Option 240</p> <p>Configure with one 1.6 GHz/18 MB dual core 9140Nprocessor module Option 260</p> <p>Configure with one 1.6 GHz/24 MB dual core 9150Nprocessor module Option 280</p> <p>Base system includes one power supply (second supply can be ordered for redundancy) and a 2 port 10/100/1000 GbE PCI X card in one core I/O slot. Must select core I/O storage controller, I/O backplane, memory carrier board option, and memory (minimum 2 GB).</p> <p>Four processor/eight core capable HP Integrity rx6600 base system with two dual core processor modules AD132A</p> <p>Configure with two 1.4 GHz/12 MB dual core processor modules Option 140</p> <p>Configure with two 1.6 GHz/18 MB dual core processor modules Option 160</p> <p>Configure with two 1.6 GHz/24 MB dual core processor modules Option 180</p> <p>Configure with two 1.4 GHz/12 MB dual core 9120Nprocessor modules Option 240</p> <p>Configure with two 1.6 GHz/18 MB dual core 9140Nprocessor modules Option 260</p> <p>Configure with two 1.6 GHz/24 MB dual core 9150Nprocessor modules Option 280</p> <p>Base system includes one power supply (second supply can be ordered for redundancy) and a 2 port 10/100/1000 GbE PCI X card in one core I/O slot. Must select core I/O storage controller, I/O backplane, memory carrier board option, and memory (minimum 2 GB).</p> <p>Four processor/eight core capable HP Integrity rx6600 base system with three dual core processor modules AD133A</p> <p>Configure with three 1.4 GHz/12 MB dual core processor modules Option 140</p> <p>Configure with three 1.6 GHz/18 MB dual core processor modules Option 160</p> <p>Configure with three 1.6 GHz/24 MB dual core processor modules Option 180</p> <p>Configure with three 1.4 GHz/12 MB dual core 9120N processor modules Option 240</p> <p>Configure with three 1.6 GHz/18 MB dual core 9140N processor modules Option 260</p> <p>Configure with three 1.6 GHz/24 MB dual core 9150N processor modules Option 280</p> <p>Base system includes one power supply and a 2 port 10/100/1000 GbE PCI X card in one core I/O slot. Must select core I/O storage controller, I/O backplane, memory carrier board option, and memory (minimum 2 GB).</p> <p>Four processor/eight core capable HP Integrity rx6600 base system with four dual core processor modules AD134A</p> <p>Configure with four 1.4 GHz/12 MB dual core processor modules Option 140</p> <p>Configure with four 1.6 GHz/18 MB dual core processor modules Option 160</p> <p>Configure with four 1.6 GHz/24 MB dual core processor modules Option 180</p> <p>Configure with four 1.4 GHz/12 MB dual core 9120Nprocessor modules Option 240</p>
------------------------	--

Technical Specifications

Configure with four 1.6 GHz/18 MB dual core 9140N processor modules	Option 260
Configure with four 1.6 GHz/24 MB dual core 9150N processor modules	Option 280
Base system includes one power supply and a 2 port 10/100/1000 GbE PCI X card in one core I/O slot.	
Must select core I/O storage controller, I/O backplane, memory carrier board option, and memory (minimum (2 GB)).	
Server Form Factor (Required - Must choose either field rack kit, factory rack integration, or optional standalone mount)	
Please refer to the HP 10000 Series G2 Rack Best Practices Guide for information on rack deployment, stabilization and transportation. (http://www.HP.com/go/rackandpower)	
Universal Rack Kit	AD053A
Field Rack Kit	B01
Includes rack slides and cable management arm	
Factory Rack Integration	OD1
For factory rack integration, a rack cabinet must appear in the same section of the order. The slides and cable management arm will be installed with the server in the rack cabinet when factory rack integration is ordered.	
Optional Stand-Alone Pedestal Form Factor	AD308A
NOTE: Will not be factory configured, will be shipped in a separate box for field installation only.	B01

Supported Processors	1.6-GHz Dual-core Intel Itanium Processor	AD238A
	Cache-On-Chip Level 1	32-KB
	Cache-On-Chip Level 2	1-MB Instruction/256-KB Data (per core)
	Cache-On-Chip Level 3	24-MB (12-MB per core)
	Floating point Coprocessor included	Yes
	1.6-GHz Dual-core Intel Itanium Processor	AB580A
	Cache-On-Chip Level 1	32-KB
	Cache-On-Chip Level 2	1-MB Instruction/ 256-KB Data (per core)
	Cache-On-Chip Level 3	18-MB (9-MB per core)
	Floating point Coprocessor included	Yes
	1.4-GHz Dual-core Intel Itanium Processor	AB579A
	Cache-On-Chip Level 1	32-KB
	Cache-On-Chip Level 2	1-MB Instruction/256-KB Data (per core)
	Cache-On-Chip Level 3	12-MB (6-MB per core)
	Floating point Coprocessor included	Yes
	1.6-GHz Dual-core Intel Itanium 9150N Processor	AD388A
	Cache-On chip Level 1	32 KB
	Cache-On chip Level 2	1-MB Instruction/256-KB Data (per core)
	Cache-On chip Level 3	24-MB (12-MB per core)
	Floating point Coprocessor included	Yes

Technical Specifications

1.6-GHz Dual-core Intel Itanium 9140N Processor	AD389A
Cache-On chip Level 1	32 KB
Cache-On chip Level 2	1-MB Instruction/256-KB Data (per core)
Cache-On chip Level 3	18-MB (9-MB per core)
Floating point Coprocessor included	Yes
1.4-GHz Dual-core Intel Itanium 9120N Processor	AH231A
Cache-On chip Level 1	32 KB
Cache-On chip Level 2	1-MB Instruction/256-KB Data (per core)
Cache-On chip Level 3	12-MB (6-MB per core)
Floating point Coprocessor included	Yes

NOTE: Two power cords are shipped with each system; one that connects the system to the rack PDU and one that enables direct connection to a wall socket. The cord that connects the system power supply to the PDU has an IEC 19 end, which plugs into the system power supply's IEC 20 socket, and an IEC 20 end, which plugs into the PDU's IEC 19 socket. The localized cord that connects the system power supply directly to the wall socket has an IEC 19 end, which plugs into the system power supply's IEC 20 socket, and a country specific end, which plus into the wall socket. This localized cord is included at the distribution site.

System Memory	Minimum memory	2-GB
	Maximum memory capacity	192-GB

Internal Disks	Maximum disk mechanisms	16
	Maximum disk capacity	2,336 GB

NOTE: Maximum of 2,336 GB of disk is achieved with 146-GB GB disk. A 300 GB SAS disk will be available for all operating systems at a later release.

Standard Integrated I/O	Serial Attached SCSI (SAS)	8 ports
	Please see specific system offerings for details	
	10/100/1000Base T (RJ 45 connector)	2 ports
	RS-232 serial ports	2
	10/100Base T management port (RJ 45 connector)	1
	USB (2.0) Ports	1 front/2 rear
VGA	Optional for HP UX, Linux, OpenVMS. Required for Windows.	

Technical Specifications

I/O Buses and Slots (Must select 1 only)	I/O Backplane Option	AD296A
	PCI-X 2.0 Backplane	Option 100
	Available I/O slots	8
	Two 266 MHz, 64 bit slots, each on its own dedicated PCI X bus	
	Two 133 MHz, 64 bit slots, each on its own dedicated PCI X bus	
	Four 66 MHz, 64 bit slots distributed on 2 PCI X buses; 2 slots per bus	
	PCI-Express Backplane	Option 200
	NOTE: Not supported with HP-UX 11i v3 at this time.	
	Available I/O slots	8
	Two x8 PCI-Express slots on one 1.3-GB/s bus	
Two x8 PCI-Express slots, each on its own dedicated 2.6 GB/s bus		
Two PCI-X 133-MHz, 64-bit slots, each on its own dedicated bus		
Two PCI-X 66 MHz, 64 bit slots distributed on 1 PCI X bus		

Maximum I/O Cards (See supported I/O table for product specifics)	Additional Interface Cards	8
--	----------------------------	---

Electrical Characteristics	AC Input power	200-240V 50-60Hz
	Hot swap Power supplies	1 included, 2nd for N+1
	Redundant AC power inputs	1 included, 2nd for N+1
	Maximum input current at 200V	10 A
	Typical power dissipation	998 Watts
	Maximum power dissipation	1,633 Watts
	Power factor at full load	0.95 or higher
	Typical heat dissipation (BTUs/hour)	3,405
	Maximum heat dissipation (BTUs/hour)	5,572
Maximum heat dissipation (BTUs/hour)	5,572	

Site Preparation	Site planning and installation included	No
	NOTE: System is customer installable.	
	Rack system Depth	696 mm/27.4 in
	Rack system Width	440 mm/17.32 in
	Rack system height (EIA/mm)	306 mm/12.0 in/7 U
	Rack system Weight (kg/lbs) maximum	68 kg/150 lbs
	Pedestal system Depth	696 mm/27.4 in
	Pedestal system Width	489 mm/19.3 in
	Pedestal system Weight (kg/lbs) maximum	86 kg/189 lbs

Technical Specifications

Environmental Characteristics	Acoustics (operator/bystander) at 77° F (25° C)	<6.9 Bels LwA
	Operating Temperature (up to 5000 ft/1524 m)	41° to 95° F (5° to 35° C)
	Max. rate of temperature change, operating	30 per hour
	Non-operating Temperature	5° to 35° F (-40° to 70° C)
	Maximum rate of temperature change, non operating	20° per hour
	Operating relative humidity	15% to 80% RH non-condensing
	Non operating/storage humidity	5% to 95% non-condensing
	Operating altitude above sea level	10,000 ft (3,000 m) maximum
	Non-operating altitude above sea level	15,000 ft (4,600 m) maximum

NOTE: Two power cords are shipped with each system; one that connects the system to the rack PDU and one that enables direct connection to a wall socket. The cord that connects the system power supply to the PDU has an IEC 19 end, which plugs into the system power supply's IEC 20 socket, and an IEC 20 end, which plugs into the PDU's IEC 19 socket. The localized cord that connects the system power supply directly to the wall socket has an IEC 19 end, which plugs into the system power supply's IEC 20 socket, and a country specific end, which plugs into the wall socket. This localized cord is included at the distribution site.

Regulatory Compliance	RMN	RSVLA-0405
	Electromagnetic interference	Complies with FCC Rules and Regulations, Part 15 as a Class A digital device. Manufacturer's Declaration to EN55022 Level A, VCCI Registered, Class A, Korea RLL.
	Safety	UL Listed, CSA Certified, TUV GS Mark compliant with EN 60950 and EN 41003
	More detailed regulatory documents and certifications	http://docs.hp.com/en/hw.html

© Copyright 2008 Hewlett-Packard Development Company, L.P.

The information contained herein is subject to change without notice.

Intel and Itanium are registered trademarks or trademarks of Intel Corporation in the U.S. and/or other countries.

The only warranties for HP products and services are set forth in the express warranty statements accompanying such products and services. Nothing herein should be construed as constituting an additional warranty. HP shall not be liable for technical or editorial errors or omissions contained herein.